

Reverb Tank
 8AC2B1B worked well, more should work well
 10R input impedance 12K output
 i use a stereo male plug jack in a trs connector to send and receive to the tank
 connect sleeve to ground if your reverb tank is output grounded

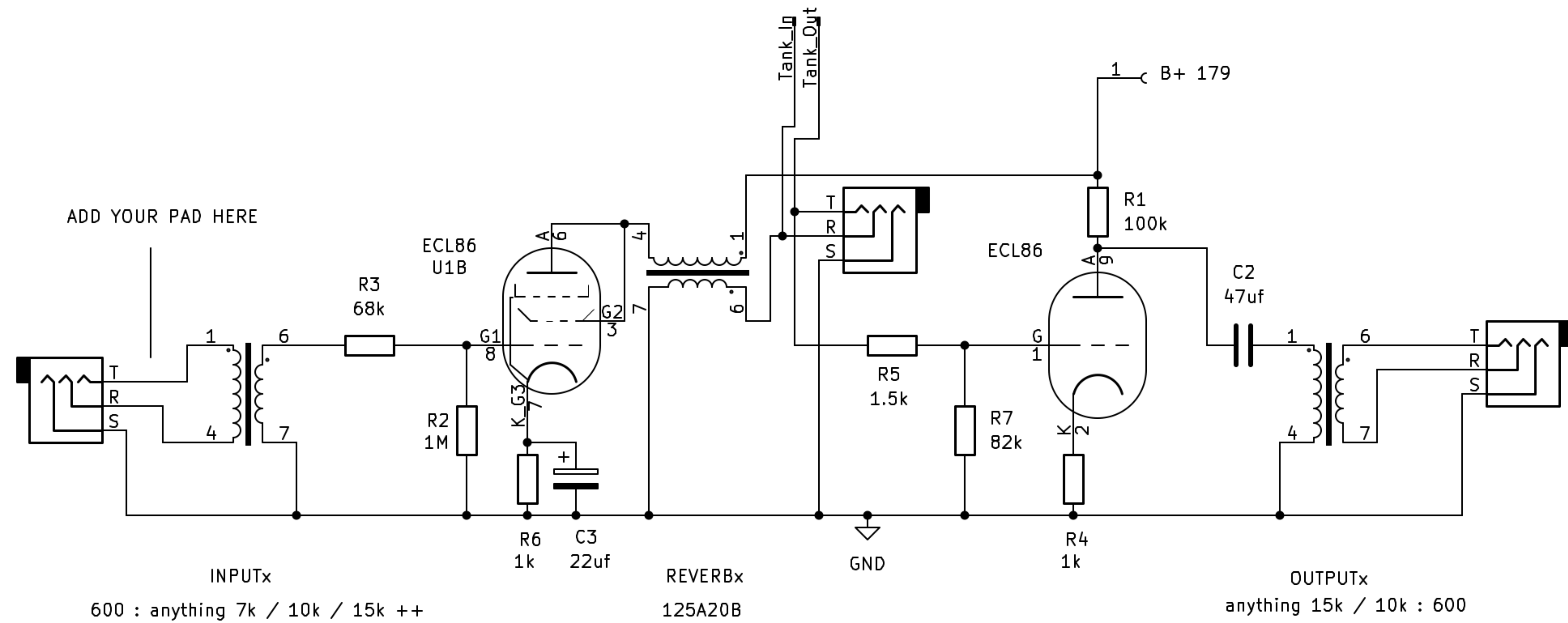

INPUTx
 600 : anything 7k / 10k / 15k ++

REVERBx
 125A20B
 15k/4R, but it can be anything, i used it because i had it + tank! Use something that matches the input impedance of your tank

OUTPUTx
 anything 15k / 10k : 600

R7: i picked that value to have a compressed / dimmed spring sound, darker sounding
 You can try other values there if you'd like a more open / high frequencies sound
 R7 could even be a potentiometer if you want an output volume!